

Monitoring of Oil Composition by an Automated System for Esterification—GC Analysis

E. BITNER, T.L. MOUNTS and H.J. DUTTON, Northern Regional Research Center, Agricultural Research, Science and Education Administration, U.S. Department of Agriculture, Peoria, IL 61604

ABSTRACT

An automatic system for transesterification of fats and oils was developed and coupled with an auto-injector type gas chromatograph. Using a timer sequencer, electronic valving for sample and reactant solution introduction and appropriate pumps and a real-time computer, the system permits programmed monitoring of vegetable oil for fatty acid composition. The system can be used with batch or continuous reactors to determine the progress of composition modification and in processing streams to confirm uniformity of incoming stocks or finished products.

INTRODUCTION

Process gas chromatographs (GC) (1) are commercially available and widely used in industry, especially as on-stream analyzers (2) in petroleum refineries. Similar developments for vegetable oil refineries have not been made although automation within the field is well established (3-5). This is probably because with vegetable oils, an additional reaction complicates the GC procedure; it is necessary to monitor fatty acid composition as methyl ester derivatives, not as triglycerides (6,7). The transesterification reaction to convert glycerides to monoesters is most frequently carried out as a batch reflux operation and is not readily amenable to automation. This manuscript describes an automatic method for preparing vegetable oil methyl esters and their GC analyses. The automatic procedure will complement on-stream analyzers and systems automation by permitting programmed analysis of the composition of oils from modification reactions.

EXPERIMENTAL

Transesterification

The improved reaction was based on the Christopherson and Glass preparation of milk-fat methyl esters, which is carried out at room temperature (7). Changes were made in the reactant solution to make it single phase and minimize required equipment. Sodium methoxide solution (0.5 M-powdered NaOCH_3 in ACS grade methanol [CH_3OH]) was mixed with ACS grade ethyl ether in a 1:1 ratio. The ether substituted for hexane gives a single phase and aids in dissolving the oil. Usually a precipitate occurs, but it settles readily and is removed by decanting or filtering. Storage of the solution for 1 mo at room temperature does not affect activity. The methyl esters are formed by automatically mixing 2 to 3 ml of reactant solution and 0.25 ml of oil with stirring for 1 min.

Apparatus

Two configurations of the apparatus have been devised. The first uses a 6-way (6W) valve (Varian Aerograph, Walnut Creek, CA) that is amenable to use with oil processing flow streams. The second configuration uses solenoid pinch clamps and is used with both slurry and non-slurry streams.

The first design constructed using the 6W valve is shown schematically in Figure 1. In the circulate position shown in Figure 1a, the oil to be sampled is pumped continuously

through the 6W valve, either from a holding tank (or flask), batch or continuous reactor, or a process stream. Figure 1b shows the 6W valve in the sample position, in which a sample of oil (ca. 0.25 ml) is obtained for analysis. A sequencer (not shown but diagrams available on request) times the on-off cycles of solenoid valves (2-way [2W] and 3-way [3W]) and the 6W valve for proper mixing, injecting, draining and cleaning of reaction and apparatus.

The individual parts of the apparatus are shown in Figure 1a. A micropump (Pump A, Buchler Instr. Div., Fort Lee, NJ) was used to pump the reactant solution, since its Teflon parts are unaffected by the solution alkalinity and it is adjustable over a relatively wide range. A 4-vein peristaltic pump (Pump B, Buchler Instr. Div.) was used for the viscous oil because it has the required suction

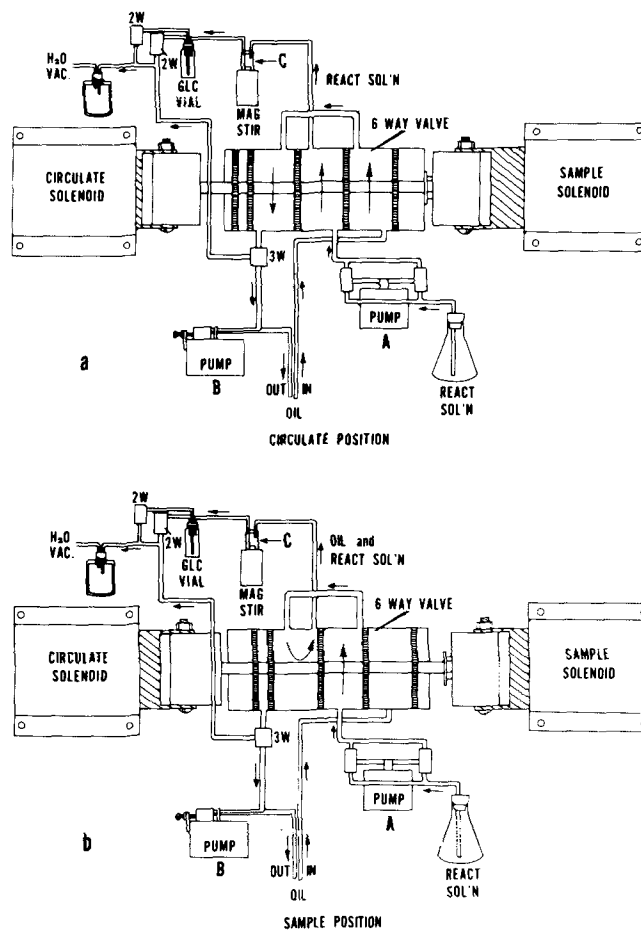

FIG. 1 (a). Diagram of automated apparatus, 6W valve in "circulate" position. 2W and 3W—2-way and 3-way solenoids. A—Reaction solution pump. B—Sample or oil pump. C—Reaction flask. Arrows indicate path of liquid depending on solenoid position. See text for further details. (b) Diagram of automated apparatus, 6W valve in "sample" position. 2W and 3W—2-way and 3-way solenoids. Arrows indicate path of liquid when flowing. See text for further details.

capacity and also is widely adjustable. Solenoid valves (2W and 3W) also were constructed with inert Teflon parts (General Valve Corp., E. Hanover, NJ). The 6W valve was operated by solenoids having ca. 9-lb pull capability which was required because the valve "O" rings tend to seat after a short period of inactivity (1/2 hr or longer).

Selection of appropriate "O" rings for use in the 6W valve was of particular importance; they had to be inert to relatively strong alkaline solution. The poor elasticity of Teflon made it unsatisfactory for use since the "O" rings are required to stretch considerably during installation. Viton and natural rubber "O" rings decomposed upon contact with the reactant solution and tended to plug the 6W valve. Although soaking of silicon "O" rings in the reactant solution resulted in total decomposition within 2 days, they operated satisfactorily in the 6W valve by flushing out the solution with methanol when the valve was not in use.

The tubing used throughout the apparatus was silicone "medical" type tubing that resists attack by oil and reactant solution. Decomposition of the tubing will occur if it is allowed to be in contact with concentrated alkali; therefore, during extended periods of inactivity (24 hr or especially 3 to 4 days), the tubing was flushed with CH₃OH (ACS grade) and air. This was accomplished by activating the cleaning solenoid and sucking CH₃OH through the system with the water aspirator.

The 6W valve design performs satisfactorily with clear filtered oil streams. However, attempts to use the apparatus with catalyst slurries, e.g., from hydrogenation reactions, resulted in blockage of the 6W valve.

An alternative sample transport configuration was devised and the operational diagram is presented in Figure 2 as showing 8 solenoid-mounted pinch clamps. Use of a relay control chassis and minor rewiring modifications of the timing sequencer were required for this version of the

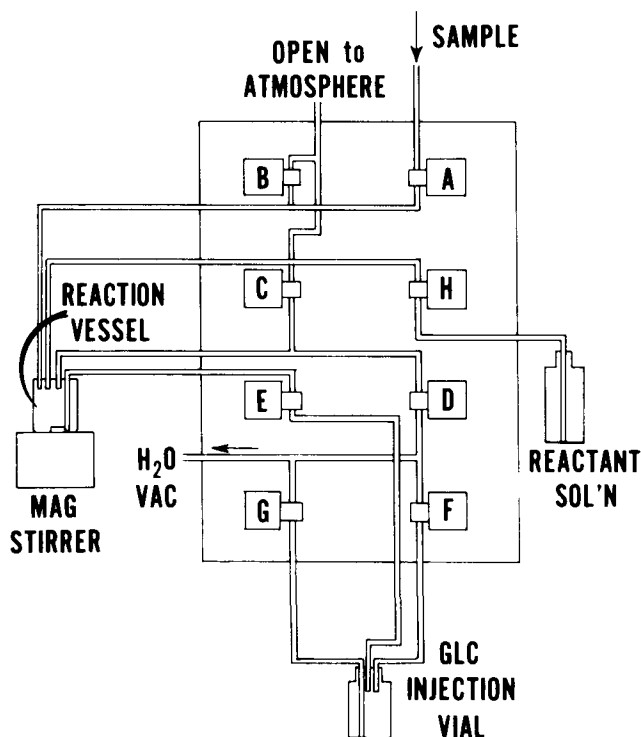

FIG. 2. Diagram of automated apparatus using the solenoid pinch-clamp arrangement. A through H—solenoids. Lucite mounting frame dimensions with solenoids installed 14-3/4 in. L x 8-1/4 in. W x 6 in. H. See text and Fig. 4 for further details.

apparatus.

A rubber-stoppered, 20-ml vial was used as a reaction vessel and was provided with a small teflon-clad magnetic stirring bar to give agitation and to ensure rapid reaction. Inlet and outlet of sample and reactant solution was through 1/8-in id stainless steel tubing. A standard equipped GC vial and septum for use with automatic samplers was modified by permanent placement of 16-gauge needles for filling and evacuating as shown.

Any automatic injector-type GC may be used by deactivating the sample advance mechanism. Synchronization of the sequencer and GC was accomplished by connecting the appropriate built-in "remote" contacts on the GC to a relay in the sequencer.

Operational Procedure

By referring to the 6W valve apparatus diagram (Figs. 1 a and b) for liquid flow and the diagram for timing (Fig. 3), the complete reaction sequence can be followed: (a) cleaning solenoid activates and air is sucked from the reaction flask through the injection flask. Air is used to clear lines; (b) the 6W valve goes to the sample position and the reactant solution pump (A) is activated. Sample is taken; (c) 6W valve returned to circulate position and oil drain solenoid is activated; (d) "filling" solenoid is activated. Vial on GC is filled with esterified sample; (e) GC automated injector is activated. Sample is injected into GC; and (f) cleaning solenoid and reactant solution pump (A) are activated. Complete system is cleansed with reactant solution (tubing, reaction vessel and GC vial).

With the solenoid pinch clamp configuration installed, the reaction sequence is quite similar to the 6W valve design except that no pumps are involved and electronic sequencing is for the on-off cycle of the solenoids. A water aspirator (vacuum) pulls the sample and/or reactant solution into the proper container for either reacting or cleaning, depending on the solenoid's position. There is no recirculation of the process stream through an external

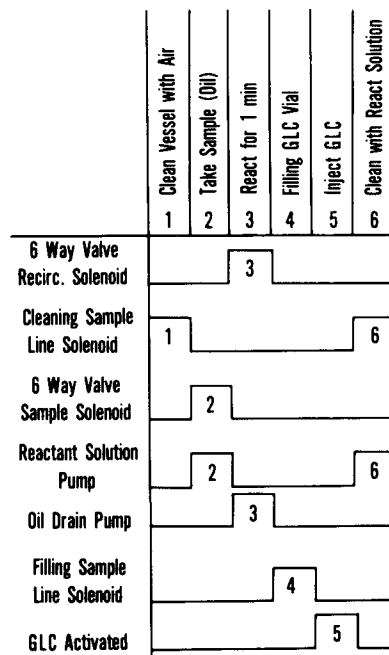

FIG. 3. Operational sequence and timing diagram. High level line shows apparatus activated (on), low level line shows apparatus inactivated (off). Total time for operation as diagrammed is 8 min. Apparatus affected and event is given at left and top of diagram, respectively.

valve, rather a sampling tube is inserted into the reaction stream or vessel for sample withdrawal.

Experimental Application

Soybean oil (50 ml) was hydrogenated in an all-glass batch manometric apparatus at room temperature using 0.05% palladium (5% palladium on carbon, Engelhard Industries, Newark, NJ) by weight of oil. The reaction flask was modified to include a sampling tube, and samples were taken automatically during the course of the reaction using the solenoid pinch-clamp configuration.

RESULTS AND DISCUSSION

The system for automated transesterification GC analysis is presented as a block diagram in Figure 4. Our primary emphasis was on development of the first block (A), automated methyl ester preparation. The analog signal from the GC hydrogen flame detector-electrometer is coupled directly to a real-time computer programmed to integrate the area under the GC curve and provide the completed compositional analysis via a remote teletypewriter located at the operational site. The automated GC and computer computations have been discussed in detail by other authors (8-11).

Operation of the apparatus with the 6W valve configuration for monitoring the composition of a tank, batch, or stream of unhydrogenated soybean oil is shown by the analyses presented in Table I. The fatty acid compositional analyses for successive methyl ester preparations were identical within the limits of error and indicate the excellent reproducibility of the automated procedure. Thin layer chromatography (TLC) ($\text{CHCl}_3/\text{C}_6\text{H}_6$ [70:30]

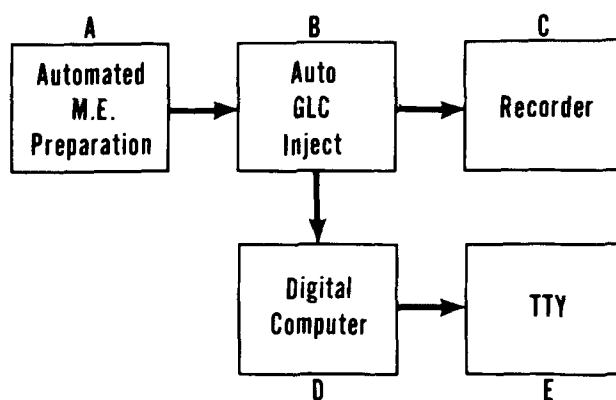

FIG. 4. Block diagram of complete automated system. Block A—original development described in manuscript. Blocks B, C, D and E—commercially available equipment.

eluting solvent on 0.025-mm silica gel plates) of the product of the transesterification reaction indicated 100% conversion of the triglycerides to the methyl esters.

Operation of the apparatus with the solenoid pinch-clamp configuration for monitoring the composition of batch or continuous stream slurry reactions is illustrated by the analyses presented in Table II. The hydrogenation proceeded over a period of 6-1/2 hr with an iodine value drop of 26 units. All analyses were performed on the oil-catalyst slurry. No difficulties of syringe injection were experienced from the presence of catalyst. It can be anticipated that there might be deterioration of the GC column with time resulting from the small amount of catalyst

TABLE I

Composition of Unhydrogenated Soybean Oil by Automated Transesterification-Gas Chromatography^a

Run	Fatty acid composition (wt %)				
	Palmitate	Stearate	Oleate	Linoleate	Linolenate
1	10.99	4.11	24.91	52.61	7.18
2	10.55	4.16	25.32	52.55	7.42
3	10.86	4.19	25.10	52.55	7.29
4	11.06	4.21	25.22	52.31	7.11
5	11.13	4.22	25.18	51.97	7.41
6	10.81	4.33	25.01	52.38	7.40
Mean	10.90	4.20	25.12	52.40	7.30
SD ^b	0.21	0.07	0.15	0.24	0.13

^aGC conditions: helium flow rate: 60 ml/min; column temperature: 185 C; detector temperature: 230 C; column: 6 ft x 1/4 in. aluminum column packed with 10% EGSS-X on Chromosorb P (Applied Science, PA).

^bStandard deviation.

TABLE II

Monitoring Composition of Oil by Automated Transesterification-Gas Chromatography^a: Hydrogenation of Soybean Oil

Reaction time (min)	Fatty acid composition					Iodine value
	Palmitate	Stearate	Oleate	Linoleate	Linolenate	
0	10.9	4.2	26.9	52.4	7.3	131.6
21	11.3	4.4	28.7	49.7	5.8	125.9
65	10.8	4.5	30.5	48.5	5.4	124.7
197	11.0	4.9	37.7	43.1	3.3	115.7
265	10.9	4.8	41.6	40.3	2.4	111.9
314	11.2	5.3	45.9	36.0	1.6	106.1

^aGC conditions same as in Table I.

injected with the sample.

Selection of a particular apparatus configuration using 6W valve or solenoid pinch clamps will be determined by the type of process to be monitored and availability of parts.

Since the sequencer has a 40-step potential, it can be wired in the most desirable arrangement for repeat operations, up to 40 operations and 56 min. Our original design brought all contacts to terminal strips, so one can simply jumper from one terminal to another for "programming." A "plug-in" type board could also be used to speed up the instrument reprogramming for versatility. Other sequencers can be purchased to make practically any arrangement desired.

The apparatus makes a practical addition to equipment that can be used for monitoring vegetable oil process streams and reactions, such as hydrogenations (12).

Schematics and diagrams of the sequencer have been excluded for space-saving and simplicity but may be obtained by contacting the authors.

ACKNOWLEDGMENTS

The assistance and guidance of our in-house shops: e.g., photography, instrument, glass, are gratefully acknowledged.

REFERENCES

1. Villalobos, R., *Anal. Chem.* 47:983A (1975).
2. Sandford, J. *Instrum. Control. Syst.* 50:25 (1977).
3. Duff, A.J., *JAOCS* 53:370 (1976).
4. Bitner, E.D., J.M. Snyder, J.O. Ernst and H.J. Dutton, *Fette, Seifen, Anstrichm.* 79:483 (1977).
5. Bryant, G.E., F. Sullivan and K. Robe, *Food Process.* 35:56 (1974).
6. Metcalfe, L.D. and A.A. Schmitz, *Anal. Chem.* 33:363 (1961).
7. Christopherson, S.W. and R.L. Glass, *J. Dairy Sci.* 52:1289 (1969).
8. Slover, H.T. and B.S. Mason, *J. Chromatogr. Sci.* 14:40 (1976).
9. Johnson, J.H., E.E. Sturino and S. Bourne, *J. Environ. Sci. Health-Environ. Sci. Eng.* A11(2):165 (1976).
10. Baumann, F., A.C. Brown III, S.P. Cram, C.H. Hartmann and J.-L. Hendrickson, *J. Chromatogr. Sci.* 14:177 (1976).
11. Emery, E.M., *Ibid.* 14:261 (1976).
12. Dutton, H.J., *JAOCS* 51:407 (1974).

[Received February 19, 1980]

✧ Potentialities of Oilseed Flours and Proteins for Replacing Black Gram Components in the Texture of Leavened Foods

N.S. SUSHEELAMMA and M.V.L. RAO, Discipline of Biochemistry and Applied Nutrition, Central Food Technological Research Institute, Mysore 570 013, India

ABSTRACT

Defatted peanut and sesame flours in aqueous dispersions exhibit good surface activity ascribable to their protein content and comparable to that of black gram. Soy flour possesses twice as much surface activity as the other flours. Contrasted with black gram, foam matrices obtained with these dispersions are unstable to heat and have low viscosities. Addition of viscous polysaccharide stabilized the foam against thermal disruption. Oilseed flours appear to qualify as good alternatives for the surface active component and viscous hydrocolloids such as guar gum or gelatinized starch may be alternatives for the arabinogalactan of black gram. This combination effectively replaces the pulse in imparting the characteristic soft, spongy texture to leavened foods.

INTRODUCTION

Oilseed flours are the most promising protein sources to augment the lean food protein supplies in the burgeoning populations of developing countries whose staple foods are cereals, millets and tubers. Many of the oilseed proteins can supplement (1) the nutritive value of cereal proteins because of their high lysine content. Even in advanced countries there is an increasing trend toward greater use of vegetable proteins (2-7), particularly the oilseed meals and protein isolate derivatives, for fabricating animal feeds and human foods (8-10) such as baked foods, snack foods, simulated animal foods and emulsifiers. For these purposes, either the natural functional properties of the proteins are exploited or their properties modified by chemical, enzymatic or physicochemical means (11-13).

In earlier publications (14-17) we have demonstrated that the soft, spongy texture of leavened food preparations such as the *idli*, which contains black gram, results from the cooperative functioning of the highly surface-active pro-

teins (15) and the highly viscogenic arabinogalactan (16) present in the legume. The arabinogalactan helps hold the leavening gases and prevents disruption of the protein-foam (spongy texture) by heat at culinary temperatures (17). In the follow-up studies, these observations have been extended to ascertain the feasibility of replacing the foam-forming protein components with oilseed flours and the other requirements for the effective generation of the spongy texture analogous to the leavened foods based on the legume. Preliminary examination indicated that defatted peanut, sesame and soybean had adequate surface activity and further studies were confined to these readily available oilseeds. The results are discussed in this communication.

MATERIALS AND METHODS

Peanut, sesame and soybean seeds were purchased from the local market, cleaned and stored at 5-7 C in sealed containers until use.

Peanut seeds were dried at 35-40 C for 2-3 hr, decuticled, flaked and solvent-extracted in Soxhlet apparatus with petroleum ether (40-60 C bp) to remove the fat. The residue was air-dried and powdered in an Apex grinder to get peanut flour (80 mesh).

Sesame seeds were soaked in water for 10-12 hr at room temperature (22-25 C), drained and dehusked by rubbing over a gunny bag. Seeds were air dried and winnowed/aspirated to remove the husk, flaked, defatted and powdered to get sesame flour.

Soybean seeds were dehusked, split and flaked after adjusting the moisture to 10-12%, then defatted and powdered to form soybean flour. Black gram flour (100